

SPRING-TOOTH, HEAVY TOOTH, HEAVY TOOTH DRAG HARROWS

LIRA

LARI

LIRA XS

LIRA XL

DINAR



**LOZOVA
MACHINERY**

MAKE YOUR MONEY WORK!

CONTENTS



LIRA
Hydraulic spring-tooth wide level harrow

p. 3



LARI
Heavy tooth drag harrow and mineral fertilizers

p. 7



LIRA XS
Light spring harrow

p. 9



LIRA XL
Heavy tooth harrow

p. 12



DINAR
Rotary harrow

p. 15

Harrowing



LIRA

HYDRAULIC SPRING-TOOTH
WIDE LEVEL HARROWS



TRADITIONAL
and ORGANIC

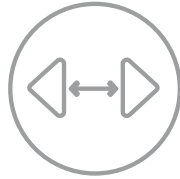

15-24 m



min 80 hp

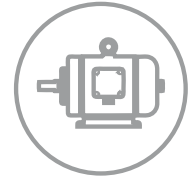

max 28,8 ha/h

LEGENDARY LIRA

The LIRA spring harrow is applied for:

- early spring harrowing for crust destruction and encouraging the weeds germination;
- weeds destruction in the “white fiber” phase;
- moisture retention by means of interruption of capillary flow from the substrate;
- even distribution of stubble remains on the field;
- incorporation of seeds and mineral fertilizers, distributed across the field;
- overall tillage when handling the fallow lands and seedbed preparation when fall-ploughing;
- windrowing of straw and hay.



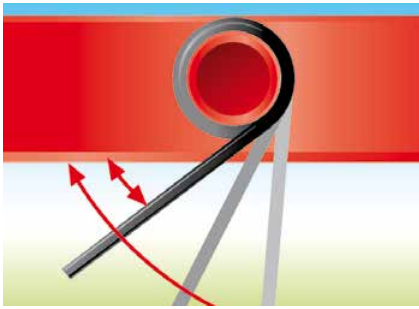

Improved tillage quality

Work sections consist of five rows of the offset spring teeth with spacing of 38 mm between them. Such arrangement doesn't leave non-cultivated areas on the field.

Careful cultivation is provided by the adjustable tilt angle of teeth. The teeth tilt angle is adjusted for entire section with limits from 15° to 90°, and interval of 15°.

Blockage-free work of teeth and perfect loosening are provided by vibration effect.



Premium class spring tooth

The spring tooth diameter is 10 mm, but application of innovative hardening significantly (in 2-3 times) increases the tooth wear resistance accounting for the torque stresses.

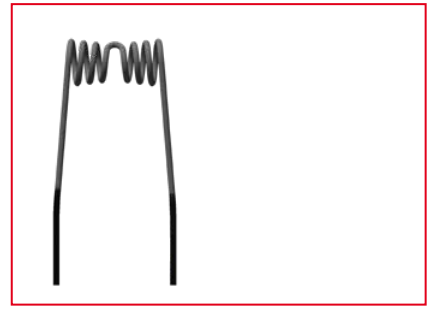

Good tooth lifetime

The spring tooth is made of high-quality special steel with special heat treatment: general bulk hardening and additional HFC hardening of ends up to 51-57 HRC.

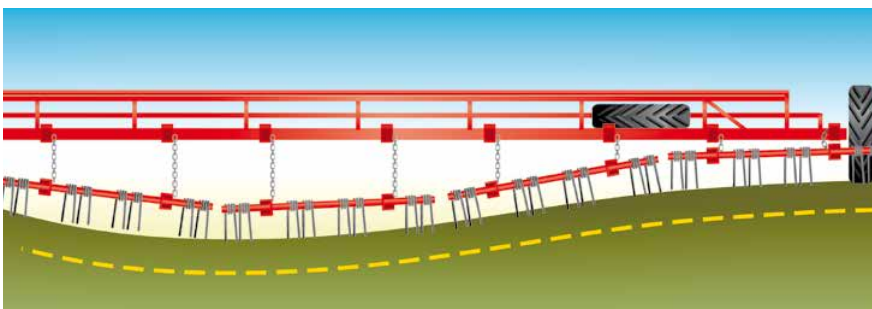
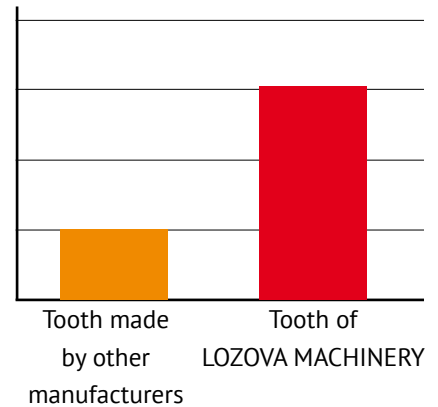

Precise and careful soil treatment

Having the chained individual working sections, the LIRA spring harrow perfectly follows any field contours in spite of its wide working width.

Special agricultural low-pressure tires almost fully eliminate the risk of damage to plants. Also there tires eliminate overcompacting of the soil and don't leave tracks.



Forged cross

Forged crosses compared to welded ones provide high durability and reliability regardless of "human factor".



Technological advantages complex

Due to simultaneous incorporation of the applied spray material, the REAL unit allows achieving the most effective incorporation and minimizing of the agent consumption, as well as environmental impact (due to lower application rate), and reducing the number of the unit passes.

REAL is equipped with a brake system.



PTO drive

For the uniform distribution of the spray material along entire working width, the REAL module is assembled with the ARAG high-quality control panel and the Annovi Reverberi axialpiston pump with tractor PTO drive.

The unit is equipped with a brake system which enhances the operating safety.



Complex for higher productivity

The REAL unit can be easily mounted to any other standard LIRA springtooth harrow, as well as with spring harrows from other manufacturers, because it is fixed to frame by U-bolts.

FERTILIZER MODULES



REAL

UNITS FOR SPREADING OF PLANT PROTECTING AGENTS AND COMPLEX FERTILIZERS



Advantages LIRA M

- Telescopic rigid rod to prevent spontaneous convergence of the half-frames during sharp turns in the transport position.
- Hydraulic control of the transport wheel for easy folding / unfolding
- Splitting the boom into two parts with the ability to install the fertilizer tank directly on the boom.



Tooth harrows LIRA of the “M” series have a reduced transport width of 3 meters corresponding to traffic regulations of the EU countries

3 m

TECHNICAL DATA

	LIRA-15	LIRA-24	NEW		REAL-15+ LIRA-15	REAL-24+ LIRA-24
			LIRA-21M	LIRA-24M		
Working width, m	15	24	21	24	15	24
Tractor power, hp.	min 80	min 130	min 110	min 130	min 80	min 130
Tractor power, hp.	trailed		trailed		trailed	
Basic weight, kg	2030	3160	2950	3280	1090	2200
Number of working tools	200	320	280	320	30	48
Teeth spacing, mm	38		38		—	
Tank volume, m ³	—		—		2,5	5,0
Teeth tilt angle, °	15, 30, 45, 60, 75, 90		15, 30, 45, 60, 75, 90		—	
Pump performance, l/min.	—		—		185	250
Operating depth, cm	max 9		max 9		—	
Operating speed, km/h	8-15		8-15		8-15	
Efficiency, ha/h	max 18	max 28,8	max 24,8	max 28,8	max 18	max 28,8
Fuel consumption, l/ha	0,8...1,5		0,8...1,5		1,0...1,8	
Transport dimensions (length x width x height), mm	10455x 3710x2390	17190x 4400x2460	16080x 3000x2400	17580x 3000x2400	13876x 4200x2460	21600x 4400x2460

Harrowing



LARI

HEAVY TOOTH DRAG HARROW



TRADITIONAL
and ORGANIC

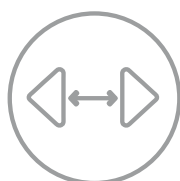

6,8-21 m



min 80 hp

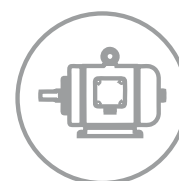

max 25,2 ha/h

PERFECT EVEN FIELD

LARI drag harrow is a universal, simple and reliable implement with high efficiency and low fuel consumption.

Main application - soil loosening and levelling, seedbed preparation, moisture retention and weeds destruction.

LARI makes it possible to start field works earlier than other machines in any weather conditions. For example, unlike a seedbed cultivator, the drag harrow is almost insensitive to soil moisture, because there is simply nothing to stick and block due to design.





Durable rhomb-shaped tooth

The most durable tooth on the market is made of special spring steel with high surface hardness (55...60 HRC).



Adjustable attack angle

Two positions of teeth (active or passive) are suitable for any work conditions at depth from 3 cm to 8 cm. Sections suspended on chains provide perfect field contours following.



Module for applying granular fertilizers

LARI can be equipped with special modules for applying solid (granular) fertilizers with simultaneous processing. The modules can efficiently and evenly distribute nutrients.

LIRA XL and LARI have unified frame design which allow to transfer heavy tooth harrow into drag harrow and vice versa. Thus, buying one implement and special set of parts the farmer gets two implement for price of one.

TECHNICAL DATA

	NEW		LARI-15	NEW	
	LARI-7	LARI-12		LARI-18	LARI-21
Working width, m	6,8	11,4	14,6	17,8	21
Tractor power, hp	min 80	min 135	min 160	min 240	min 300
Coupling with tractor	semi-trailed	trailed	trailed	trailed	trailed
Weight, kg	3060	4431	5170	5850	7095
Teeth angles	22°; 40°	22°; 40°	22°; 40°	22°; 40°	22°; 40°
Working depth, cm	8	3-8	3-8	3-8	3-8
Working speed, km/h	8...15	8...15	8...15	8...15	8...15
Efficiency, ha/h	8,1	14	17,5	21	25,2
Fuel consumption, l/ha	2-3	2-3	2-3	2-3	2-3
Transport dimensions (length x width x height), mm	4500x2560 x3550	9977x3870 x3610	11650x3870 x3610	11650x3870 x 3610	16590x3870 x 3610

Harrowing



LIRAXS

LIGHT SPRING HARROW



TRADITIONAL
and ORGANIC

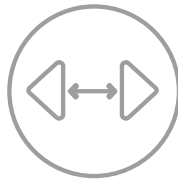

6-24 m



min 60 hp



max 25,2 ha/h

The LIRAXS spring harrow is used for harrowing the soil, and to destroy the soil crust, especially on heavy, watery soils. When processing in the upper soil layer, the system of capillary bonds is broken, a loose mulching layer is created that protects the soil from drying out.

LIRAXS is heavily used for early spring harrowing, as well as for pre-emergence and post-emergence harrowing.



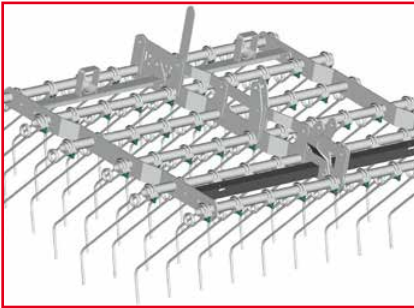

Central adjustment of the attack angle of the teeth

By means of simple adjustment with the help of the lever, sprung teeth can be adjusted for gentle or aggressive processing. The aggressiveness of the teeth is regulated centrally.

The angle of attack can be adjusted in a wide range from 20° to 90° degrees.

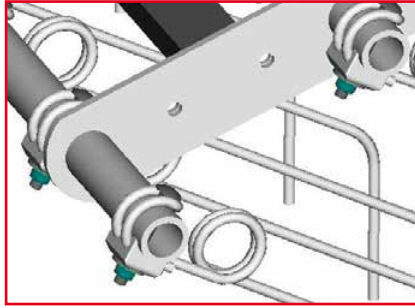

Thorough tillage

The working section has a width of 1.5 m and 60 teeth. The distance between the teeth is 25 mm.

The teeth are firmly fixed without the risk of skewing and turning during operation.

Thanks to lateral vibration of the spring teeth, in combination with a speed (10 to 15 km/h), covering surface tillage is performed.

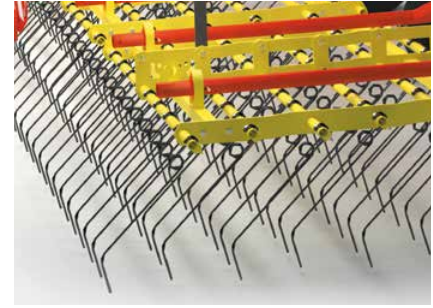

Extended work life of teeth

As standard option, the machine has a spring tooth with a diameter of 7 mm and a tooth length of 510 mm. But as per customer request, the machine can be equipped with a spring of 6 mm and 8 mm.

The special processing of the teeth guarantees an extended service life (1.5-2 times higher than that of the competitors).



Simple adjustment of the machine work height

The support wheels are height-adjustable, which allows to adjust the working height of the machine.

When working on tramlines or when moving a tractor with a machine along the rows, stepless adjustment of the track width of the support wheels is possible in the range from 1.4 m to 2.1 m.



Safe and easy transportation

Harrow sections fold hydraulically into transport position right from the tractor cab. Due to the original folding system, the machine has a transport width of 3 m.

To increase the safety of transportation, reflective shields are installed as a standard option along with the set of lighting equipment.

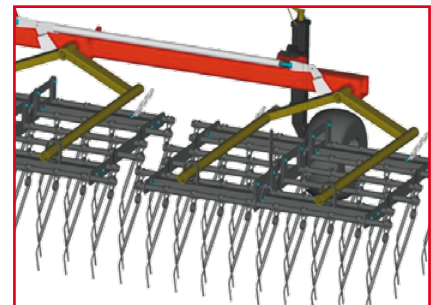

Field copying system

Sections are mounted in front on a swinging balancer, which allows to copy the topography of the soil, and also guarantees a smooth ride, especially with a large width of the harrow.

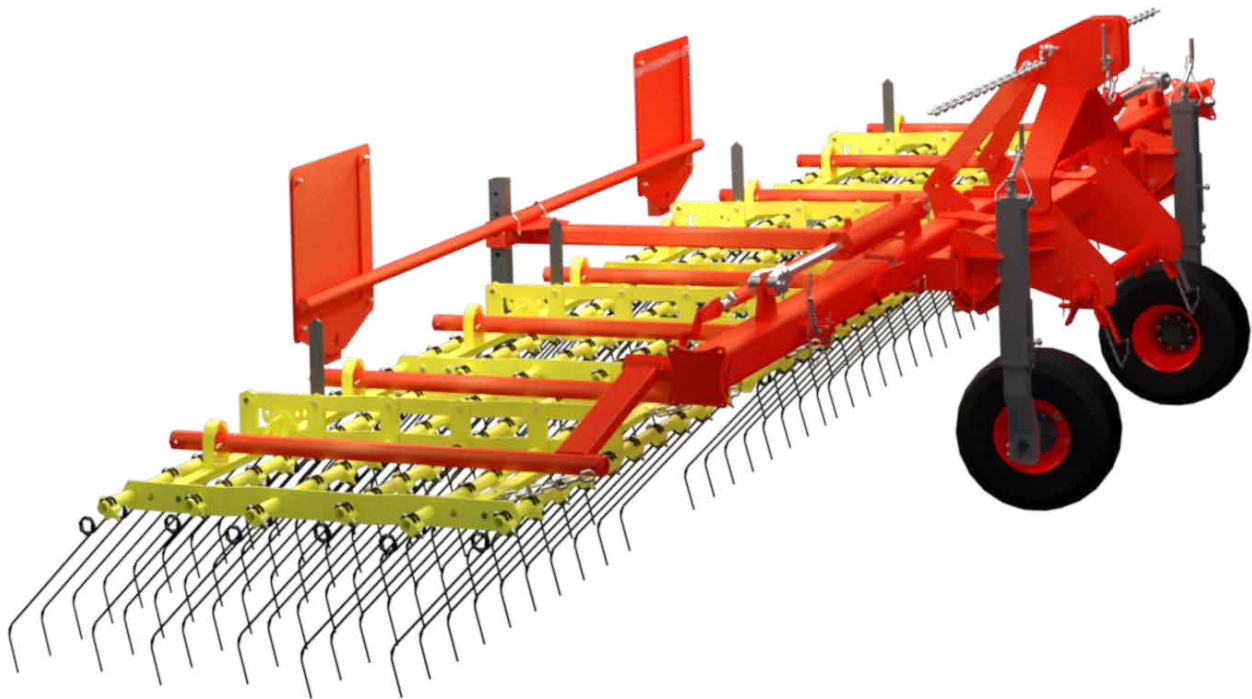

Carrying out pre-emergence and post-emergence harrowing can reduce weediness of crops by 85-95%, which is especially important when applied without the herbicidal technology of growing crops.

With the timely use of the machine, small weeds in the white filament stage, break out, and stronger cultivated plants remain intact.

LIRA XS can also be used for caring for meadows: for destroying mole passages and loosening the turf.

TECHNICAL DATA

	LIRA XS-6	LIRA XS-9	LIRA XS - 15	LIRA XS- 24
Working width, m	6	9	15	24
Tractor power, hp.	min 60	min 80	min 80	min 130
Coupling with tractor	trailed		semi-trailed	
Basic weight, kg	765	1088	2250	3460
Teeth spacing, mm	25			
Teeth tilt angle, °	20; 32,5; 45; 57,5; 90			
Diameter of a spring tooth, mm	6/7/8			
Operating depth, cm	2-10			
Operating speed, km/h	8-15			
Efficiency, ha/h	max 7,2	max 10,8	max 15,7	max 25,2
Fuel consumption, l/ha	max 2			
Transport dimensions (length x width x height), mm	2204x3000 x2051	2204x3000 x3511	10455x3710 x3500	17170x4400 x3500

Harrowing



LIRA XL

HEAVY TOOTH HARROW

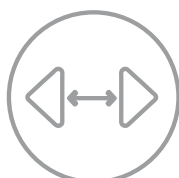

15-21 m



min 160 hp

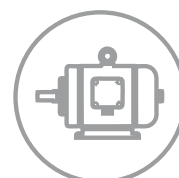

max 25,2 ha/h

NEW LEGEND

LIRA XL perfectly distributes big amount of stubble remains on the field.

It is the only harrow capable to work on dry soil in autumn, destroying soil crust and preventing moisture evaporation.

One of the unique features of the LIRA-XL is possibility to perform 5 different operations in one pass. For example, simultaneously early spring harrowing and loosening of topsoil to a depth of 2-10 cm:

- keeps moisture;
- encourages germination of weeds to be destroyed then;
- levels the soil and prepares it for seeding;
- incorporates fertilizers and pesticides;
- uniformly distributes stubble remains.





Suspension of work sections

Parallelogram suspension of separate work sections allows to keep contact with a rough soil. It provides perfect contour following alongside the whole section width and uniform distribution of load per each spring block.



Adjustable attack angle

An optimal harrowing is provided by adjustable teeth angle. Attack angle can be adjusted through the whole section within limits 45-90°.



Pressure on the soil

A spring block eliminates undesirable vibrations of sections (bouncing) at high speeds, and adjusts a pressure of the work section springs on the soil from 400 to 860 kg.



Cable tightening of sections

Flexible cables allow to simplify the design of the harrow, ensure wings rigidity and reduce stresses. They provide perfect turning maneuvering and contour following alongside the whole harrow width.



Durable teeth

Spring tooth is made of high quality special steel with double hardening. The tooth diameter is 16 mm, but due to innovative technology the wear resistance is increased in two-three times with a high strength in an area subject to the torque stresses.



Forged cross



Module for applying granular fertilizers

Forged crosses provide stable durability and reliability compared to welded ones, with no regard to human factor.

In addition to the basic operations (which LIRA XL performs in one pass), this harrow can be equipped with a special module for applying granular fertilizers.

The module consists of a strong reliable construction, polyurethane tank and accurate dosing system that provides accurate application rate regardless of the speed.

LIRA XL and LARI have unified frame design which allow to transfer heavy tooth harrow into drag harrow and vice versa. Thus, buying one implement and special set of parts the farmer gets two implement for price of one.

TECHNICAL DATA

	LIRA XL-15	LIRA XL-21
Working width, m	15	21
Tractor power, hp	min 170	min 300
Coupling with tractor	trailed	trailed
Basic weight, kg	5685	7950
Teeth spacing, mm	60	60
Teeth tilt angle, °	45-90	45-90
Diameter of a spring tooth, mm	16	16
Operating depth, cm	2–10	2–10
Operating speed, km/h	max 20	max 20
Efficiency, ha/h	max 18	max 25,5
Fuel consumption, l/ha	2-3	2-3
Transport dimensions (length x width x height), mm	11360 x 4012 x 3890	16105 x 4012 x 3890

Conservation tillage



DINAR

ROTARY HARROW



TRADITIONAL
and ORGANIC

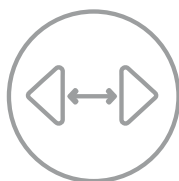

6,4 m



min 110 hp

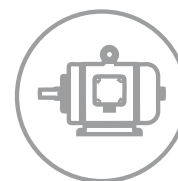

max 10 ha/h

AERATE THE SOIL

DINAR intensive rotary harrows can be used both for conventional and conservation tillage technologies.

They are designed for overall and inter-row cultivation of various cereal and tilled crops, as well as vegetables on all types of soil. These harrows are especially effective in destroying heavy soil crusts, because DINAR intensively mixes and crumbles the soil to a depth of 5 cm (operation speed is up to 20 km/h).

DINAR harrows are effective for organic tillage, as they provide maximum soil aeration and prevent sweeping of stubbles, work gently through seedlings.





Enhanced star tool

Available two variants of star with diameter of 534 mm:

- 1) ductile iron casting - durable versatile star for all kinds of works;
- 2) assembly with forged teeth - for stony soils, teeth are changable.



Additional control of penetration

The implement can be additionally equipped with support wheels to adjust depth of stars penetration into the soil.



Careful work through the seedlings

The harrow is well adapted both for overall and inter-row tillage, and able to work when the crops are already grown. With minimum inter-row distance the DINAR works from 2 leaves to 20 cm of the plant's height. At bigger inter-row distance you can work with height of up to 60 cm.



Simple and fast mounting of tines

The tines are mounted by one bolt ("fast mounting"). Thus, the less timetaking mounting – the less costs for changing tines depending on different inter-rows.



Two-stage adjustment of pressure

Precise tines pressure on a soil is provided by two springs and two-stage compression, which keeps required depth during work.



No gaps

Balance mounting of stars provides constant contact with a soil, reducing loads on bearing unit and improving the harrowing quality.



Simple transportation

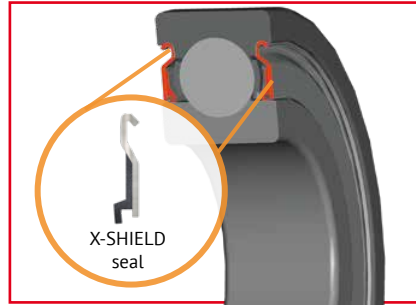

Unique reinforced bearings



Possible mounting of the spring harrow

Hydraulically folded frame ensures the harrow compactness in transport position and minimizes loads on the tractor linkage. Transport width is 3 m.

There are two reinforced ball bearings with X-SHIELD seals. Due to high accuracy of manufacture the level of noise and vibration is significantly reduced, increasing service life. Additional remote washer protects bearing from dust and stubble remains.

An additional spring harrow can be mounted in order to remove weeds from the soil and to crumble clods with additional soil loosening.

TECHNICAL DATA

	NEW		NEW	
	DINAR -6	DINAR-6,4	DINAR -9	DINAR -12,8
Working width, m	5,9	6,2	9	12,9
Tractor power, hp	min 80	min 80	min 120	min 130
Coupling with tractor	trailed	trailed	trailed	semi-trailed
Weight, kg	1270	1700	2477	4600
Number of tines, pcs	29	31	45	65
Number of stars, pcs	58	62	90	130
Number of wheels, pcs	max 5	max 5	max 5	max 5
Operation depth, cm	max 20	max 20	max 20	max 20
Operation speed, km/h	max 9	max 9,9	max 14,4	max 20,6
Efficiency, ha/h	2,5	2,5	2,5	2,5
Transport dimensions (length x width x height), mm	1377 x 2904 x 2597	1620 x 3000 x 3310	1700 x 3000 x 4000	7125 x 3000 x 2310

AREA OF SPRING, TOOTH, DRAG AND ROTARY HARROWS USE

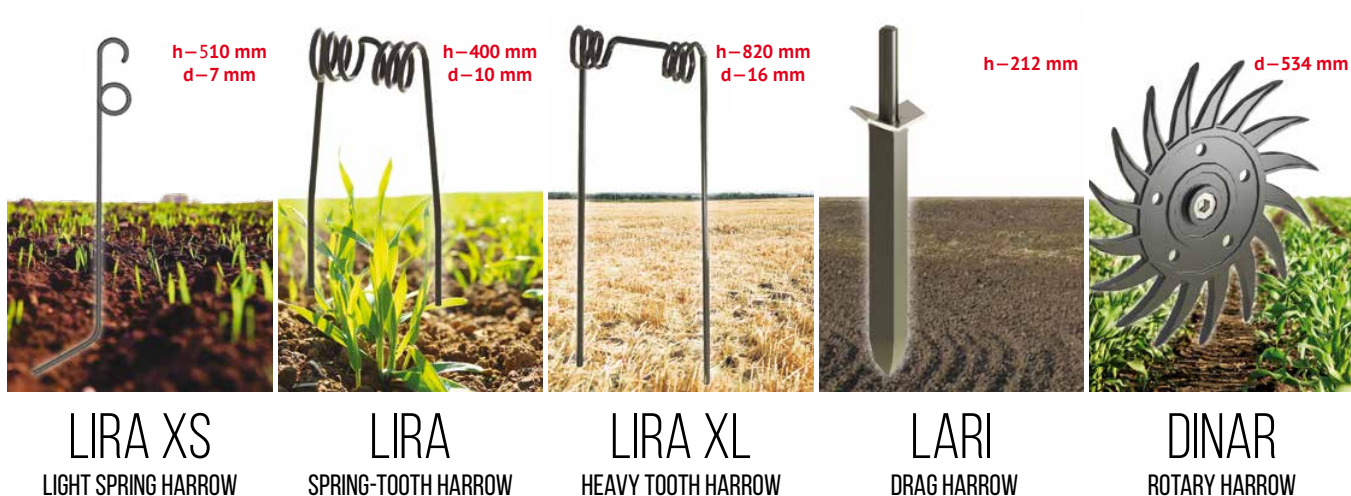

Performed operation	LIRA XS	LIRA	LIRA XL	LARI	DINAR
Light stubble plowing	-	-	+++	-	-
Distribution of crop residues	-	+	+++	-	-
Closing moisture in spring by steam	-	+	+++	+++	-
Moisture closure in spring for winter crops	+++	+++	-	-	+++
Combing out weeds in the white thread phase along the shoots	+++	+++	-	-	-
Presowing preparation on pre-plowed soil	-	+	+++	+++	-
Inter-row cultivation	-	-	-	-	+++
Aeration of the soil on shoots	+++	+++	-	-	+++
Care of the meadows	+++	+++	-	-	+

+++ optimally suitable

++ suitable

- not suitable

LOZOVA MACHINERY



DUCAT
Compact disc harrows



DUCAT GOLD
Heavy disc harrow



FRANK; GULDEN
Subsoilers



LIRA; LIRA XL
Spring-tooth harrow; Heavy tooth harrow



DINAR
Rotary harrow



CHERVONETS
Seedbed cultivator



FLORIN
Multipurpose field cultivator



SANTIM
Inter-row cultivator



ALBION XL; KELT XXL
Agricultural trailers



HARP



HARP bearings - the best bearings for agricultural machinery with X-SHIELD seals of increased tightness.

HARP AGRO UNIT - solid and maintenance-free bearing units (repairable) optimized for agricultural machinery.

4, Marshal Batitskiy Str.
Kharkov, 61038, Ukraine
+38 (057) 766-00-61
+38 (057) 766-00-62
agro@lozovamachinery.com

Join us in
social networks



lozovamachinery.com